

Clamp short with thread M16, for grooved contact wire 80-120 mm²

Item number D1081-02

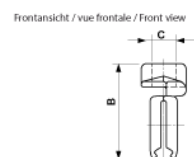
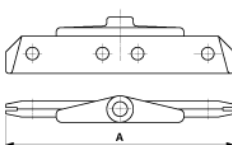
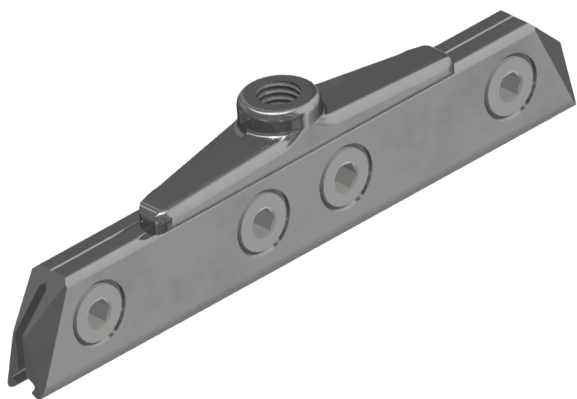

Dimensions

C: M16
A: 215 mm
B: 52 mm

Material and weight

Material: STL HDG
Weight: 0.760 kg

Comments

- For grooved contact wire 80 till 120 mm²
(Other contact wire sections on request)