

Clamp short with thread 5/8", for grooved contact wire 80 mm²

Item number D1081-03

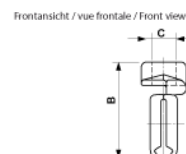
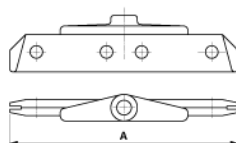
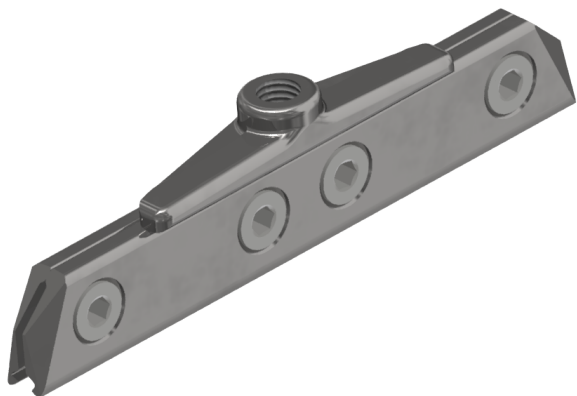

Dimensions

C: 5/8"
A: 215 mm
B: 52 mm

Material and weight

Material: STL HDG
Weight: 0.760 kg

Comments

- For grooved contact wire 80 till 120 mm²
(Other contact wire sections on request)