

# Line insulator to Unistrut channel type 3 B including suspension screws KUSYS type 2 with suspension threaded bolt M16 rigid

Item number C2383-01

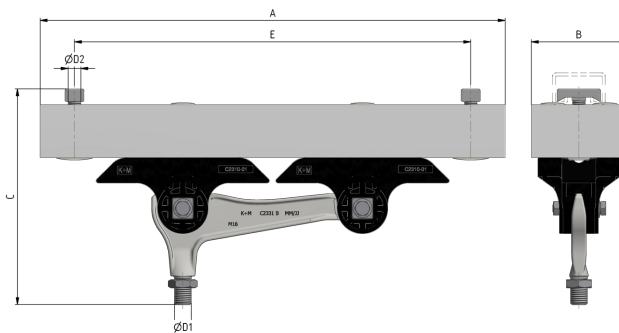

## Dimensions

A: 440 mm  
B: 90 mm  
C: 204 mm  
E: 375 mm  
ØD1: M16  
ØD2: M12

## Material and weight

Material: Kst / INOX / Alu  
Weight: 4.3 kg

## Loads

Tightening torque for bolts and hex-nuts M8: 17 Nm  
Breaking load horizontal: 1.6 kN  
Tightening torque for suspension screws M12: : 40 Nm

## Applicable standards

DIN EN 50119  
DIN EN 50124-1  
DIN EN 50151  
CEI / IEC 60060-1

## Function

Insulator body for fastening to Unistrut channel type 3B, in straight segments or slight bends. Rigid threaded bolt suspension allowing the attachment of various railway, tramway and trolley bus components.

## Specifications

Operating voltage: max. 1500 V DC

## Comments

Attachment to different types of anchoring rails on request.  
The suspension can be mounted to cross-spans or pipes by exchanging the clamp.