

Contact wire bridge electric TW according to MRL, with control box, execution right, drive tension 24 V DC

Item number B1182-24

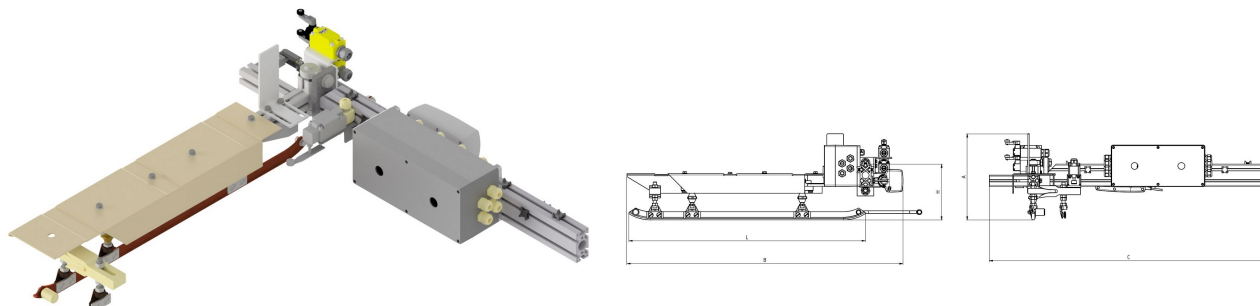

Dimensions

A: 312 mm

B: 1000 mm

C: 1013 mm

L: 860 mm

H: 202 mm

Material and weight

Weight: 16,2 kg

Material: Al, St, Cu, GFK, PA6

Function

- For bridging the catenary through a sliding gate

at Tramway depots

- Pivotal, electric drive

- No track separation, constant power supply to the tramway

Specification

Operating voltage: max. 1500 V DC

Speed: max. 20 km/h

Comments

- With control box

- For vertical and horizontal doors

- With mechanical limit switches according to Machinery Directive for signaling by signaling equipment