

Hanger wire adjustable, non conductive, with height limitation, 125-485

Item number 301112

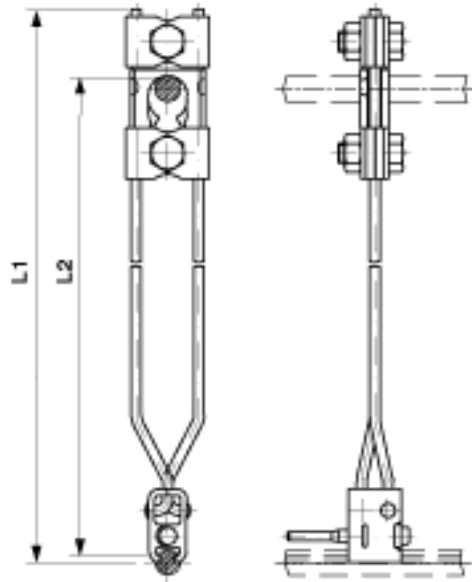

Dimensions

L1: 525 mm

L2: 125-485 mm

Material and weight

Weight: 0.450 kg

Material: CuNiSi

Loads

Load max.: 6,5 max. kN

Comments

- For contact wire 80-120 mm²
- For messenger wire 80-120 mm²
- For messenger cable 50-120 mm²
- Other types on request